

Advanced Vacuum Solutions



COVAL

vacuum managers

www.coval.com

Press release

For immediate release

Title: CVG series – Universal Vacuum Gripper

Subtitle: Standardized vacuum gripper solutions for rows, layers and structured surfaces.

*For more than 20 years, Coval has developed customized vacuum solutions for automated handling applications in the packaging, plastics, automotive and other industries. These customized systems are now available as a standard product with the introduction of the **CVG** series universal vacuum gripper which combines a high flow vacuum generator, integrated vacuum check-valves, vacuum gauge and gripper mat into one complete and compact gripper unit.*

The **CVG** is small, lightweight and energy efficient due to the advanced design which consists of an optimized multi-stage generator and patented check-valve system, lightweight and durable aluminium housing and long-lasting foam mat.

The multi-stage generator is available in 4 different sizes which can be quickly and easily interchanged in the housing of the **CVG**. These four modules make it possible for the customer to configure the vacuum gripper for optimum performance and energy savings, depending on the porosity and surface quality of the product(s) to be gripped. **CVG** is also available without integrated vacuum generator, for use with high-flow vacuum pumps on specific applications.



Utilization of Coval's patented check-valve system allows the customer to grip products of different shapes, sizes, porosities, and weights; with the same **CVG** gripper unit - *thus gaining the **CVG** its reputation as a universal gripper.* As long as 40% of the gripper's vacuum ports are in contact with a part, the check-valves in the remaining (uncovered) vacuum ports will close once the vacuum is activated. This automatic action eliminates unnecessary leaks in the vacuum gripper and allows the maximum vacuum to be achieved to assure a safe grip of the product.

The aluminium housing of the **CVG** is designed to be light weight, versatile, and easily adapted for any robot. It is available in four standard lengths (400, 600, 800 & 1200mm) with a standard width of 120mm. Custom sizes are available on request and multiple grippers can be used in series to create “row” or “layer” grippers, enabling vacuum zoning.



The foam mats of the **CVG** universal gripper are available with two standard configurations. Each version has different sized and positioned vacuum ports to provide the user with more flexibility, depending on the application requirements.

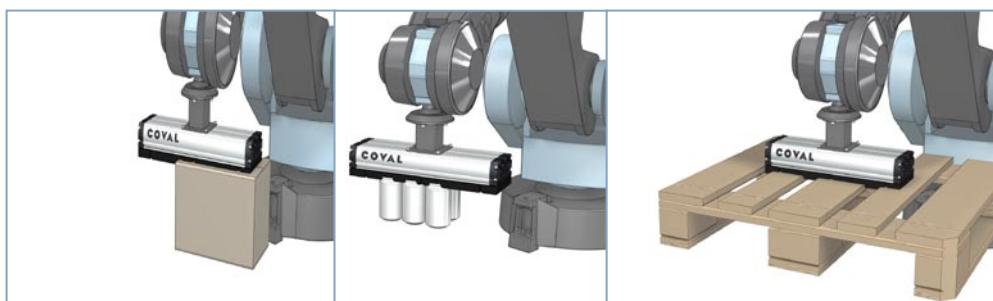

*One **CVG** universal gripper lifts boxes, pails and pallets*

Your contact @ Coval Inc.
Matt Ossi
Technical Sales Manager
Tel : (919) 233-4855
Matt.ossi@coval.com

Coval Inc.
212-112 Powell Drive
Raleigh, NC 27606
Fax : (919) 233-4854
www.coval.com